

## ASSESSMENT OF THE LOW VOLTAGE RIDE THROUGH CAPABILITY OF A SMART DISTRIBUTION TRANSFORMER WITH ON LOAD TAP CHANGER (OLTC) FOR RENEWABLE APPLICATIONS

Ron BRANDL  
Fraunhofer IEE – Germany  
ron.brandl@iee.fraunhofer.de

Gunter ARNOLD  
Fraunhofer IEE – Germany  
gunter.arnold@iee.fraunhofer.de

Pablo CIRUJANO  
Ormazabal Cotradis - Spain  
pcb@ormazabal.com

Gonzalo PEREZ DE NANCLARES  
Ormazabal Cotradis – Spain  
gpn@ormazabal.com

Luis DEL RIO ETAYO  
Ormazabal Corp. Tech. – Spain  
lre@ormazabal.com

Asier SOTO  
Ormazabal Corp. Tech. – Spain  
asd@ormazabal.com

Alena ULASENKA  
Ormazabal Corp. Tech. – Spain  
becid@ormazabal.com

Ibon LARRACOECHEA  
Ormazabal Corp. Tech. – Spain  
ilz@ormazabal.com

### ABSTRACT

*The capability to withstand the Low Voltage Ride Through tests of the control box for a smart distribution transformer with OLTC has been tested under various conditions in the Smart Grids test centre SysTec of Fraunhofer IEE -. The present project, INTREPID, has been selected for the first transnational access call of the ERIGRID project.*

### INTRODUCTION

The penetration of RES is expected to increase over the next decades. This potential rise is promoted in Europe by the European Initiative '20-20-20' [1]<sup>1</sup>, and globally by the last United Nations Climate Change Conference in Paris (December, 2015) [2]<sup>2</sup>. To fulfil their commitments, a large number of countries have set targets and policies to stimulate the development and integration of renewable energies into the electrical system [3]. Furthermore, the advancement in renewable energy technologies and engineering has boosted significantly the investment in clean energy, helping the deployment of RES [4]. In 2015, renewable energies expanded significantly in terms of capacity installed and energy produced, with renewable energy investments in the power sector outpacing net investments in fossil fuel power plants [3].

Furthermore, EV integration will be in future also an issue for the electric utilities. Whilst the integration of RES at the LV level of the distribution networks is causing overvoltages, the implementation of additional loads in the LV, such as EV, could cause steady state undervoltages.

As the European standard EN 50160 [5] defines the voltage requirements in distribution grids, and requires that the steady state voltage stays within a band of +/- 10% of the nominal voltage. The compliance with these statutory voltage limits would require a grid extension.

A smart distribution transformer with OLTC can keep the voltage inside the statutory limits by changing automatically the tap of the transformer, avoiding or minimizing the need of a conventional grid reinforcement [6, 7], and allowing further integration of distributed RES and EV [8, 9,10].

The behaviour of the system for a serious disturbance during the reverse power flow is of special interest to ensure stable network operation. Especially fast voltage disturbances from the supply grid will result in a voltage dip that will propagate to the distribution system and might trigger the disconnection of connected DG at different voltage levels depending on their Low Voltage Ride Through (LVRT) capabilities and therefore pose a threat to system stability. Network codes for DG generators varies for different voltage levels and the LVRT requirements has been applied in the past mainly for the HV and MV levels but only in few countries for the LV connected DGs.

Nowadays no grid codes are existing for a smart distribution transformer, similar requirements related to DG needs to be fulfilled in future for new components with active voltage regulation. Therefore, test procedures to investigate the grid conformity are needed to secure safe grid integration. The smart transformer operation has been assessed under various conditions in the SysTec Smart Grid test centre of Fraunhofer IEE -, designed as a platform for research, development and verification of new technologies, products, services and systems.

<sup>1</sup> To reduce CO<sub>2</sub> emissions by 20%, to reduce primary energy use by 20%, and to increase renewable energies by 20%.

<sup>2</sup> Primarily aimed at reducing global greenhouse gas emissions, setting a goal of limiting global warming to less than 2 degrees Celsius (°C) compared to pre-industrial levels.

The ability to cope with voltage fluctuations, due to the generation of energy at the LV level, and voltage dips (LVRT), promoted by electric faults on the MV or HV level of the distribution network, has been assessed - along with the algorithms used for the voltage control of the OLTC transformer. Besides, the possibility of deploying distributed voltage sensors (e.g. smart meters) has been tested in order to generate a reliable profile of the voltage along the LV grid - using an advanced algorithm.

### SMART DISTRIBUTION TRANSFORMER WITH OLTC

The described solution is based on an electromechanical OLTC that is able to change the tap position automatically, and with load, by means of a combination of fixed and movable contacts, along with a set of vacuum interrupters (two per phase) on the MV side of the transformer. The vacuum interrupters guarantee that the tap changing is performed safely because the arc, promoted by the switching process, is located inside the vacuum bottle - preventing oil pollution.

The OLTC changes the ratio of the transformer by adding or subtracting turns from the MV winding.

The smart distribution transformer complies with the international standards IEC 60076 – Power Transformers [11], IEC 60214 – Tap-Changers [12], IEC 61000 – Electromagnetic Compatibility (EMC) [13], along with the eco-design EU Directive No. 548/2014 [14]. It also can use high fire resistant biodegradable ester oil instead of mineral oil.



Figure 1. Smart transformer feeding Ormazabal Cotradis facilities<sup>3</sup>

The flat design of the patented OLTC [10] allows a compact solution, keeping the footprint of a conventional distribution transformer (to allow retrofitting).

<sup>3</sup> So far more than 24.000 OLTC operations since installation.

### ERIGRID – INTREPID project

The INTREPID project (INtelligent Transformer for Renewable Energy Prosumers Integration and Deployment) has been selected among other applicants for the 1st call of the ERIGrid Transnational Access.

ERIGrid (European Research Infrastructure supporting Smart Grid Systems Technology Development, Validation and Roll Out) is a collaborative research project supported by the Horizon 2020 Programme.

The project brings together 18 partners from 11 countries distributed all over Europe with unique and complementary DER research infrastructures and leading expertise in this field.

By providing a pan-European research infrastructure, ERIGrid supports the technology development as well as the rollout of smart grid solutions and concepts in Europe. The project jointly develops common methods, concepts, and procedures for validation of newlydeveloped smart grids solutions.

### FRAUNHOFER IEE - SysTec

The Fraunhofer IEE host research infrastructure SysTec covers the proposed research objectives. The testing laboratory for grid integration (PNI) provides the possibility to realistically develop and test grid components and grid equipment in view of new system functions, such as controllable transformers for dynamic voltage support.

In addition to the test procedures in accordance with current standards and application requirements, the investigations serve to further develop the grid connection rules.

For testing the transient behavior a mobile test equipment (LVRT test container) is available which is integrated into the central lab control as well. In this case the LVRT test container is connected in series to the MV network between the equipment under test (EUT) and the network connection point of the grid operator. It generates voltage dips on the MV side of the equipment under test without disturbing the public power grid. With the LVRT test container 3-phase as well as 2-phase faults can be generated.



Figure 2. Mobile test equipment (LVRT test container)

In the LV test bay the PNI laboratory counts with an electronic AC grid simulator (1 MVA), for replicating the energy injected from the LV side by the inverters, and programmable loads (loadbanks) with 3x 200 kW resistive load, 3x 200 kvar inductive load and 3x 200 kvar capacitive load, which may be adjusted in 1 kW and 1 kvar steps respectively.

## GRID CODE COMPLIANCE TESTS

### Standards, procedure methodology followed

Technical guidelines and standards for DG in Germany and Europe define requirements for the grid integration. The requirements depend on the maximum power capacity and the related voltage level for the grid connection of the DG. In the past LVRT capability in Continental Europe (Germany) was requested for DG with an installed capacity of more than 1 MW.

In Germany, LVRT is standard for DG directly connected to the MV-grid or higher voltage levels. DG connected to an LV-grid shall disconnect in case of voltage dips below 80 % nominal voltage within 200 ms, a dynamic grid support is not requested yet. Equipment and installations must have immunity for defined voltage dips and interruptions.

Since the application of smart transformers is of special importance for distribution grids with high DG penetration, they must fulfil at least the same standards to operate safely - although an LVRT-capability for LV-connected DG is not requested by now.

### Test setup

In order to investigate the behavior of the smart transformer under real load and grid fault conditions, the Device Under Test (DUT) is connected to a 20 kV-grid via the LVRT test container feeding different inverters and a high power load on the LV side. The test setup is shown in the following figure, whilst measurement positions are marked with VMV, VLV and VPCC.

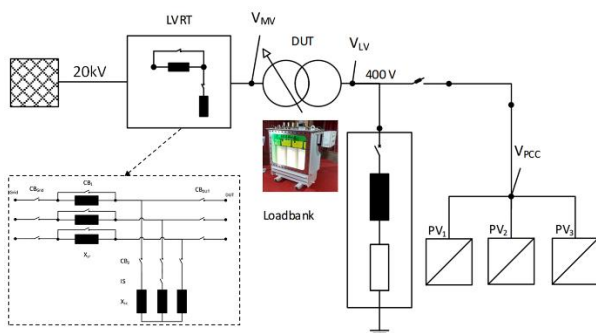

Figure 3. LVRT test general layout with the smart transformer in the Test Bay.

The LVRT test container will generate voltage dips (0.92 to 0 p.u.) at the MV-side of the DUT. An inductive voltage divider, defined by  $X_{sr}$  and  $X_{sc}$ , obtains the

required voltage dip. The series inductance  $X_{sr}$  reduces the short circuit current and hence the voltage impact to the public grid significantly. The isolator switch IS enables three-phase and two-phase dips by disconnecting of phase 2 from the short circuit. The switching of circuit breaker CB2 defines the start time and the duration of the voltage dip.

The smart transformer is a 630 kVA 20/0.4 kV Dyn5 transformer, with a short-circuit voltage of 6% and no-load losses of 600 W. The OLTC follows the reactor principle and regulates the voltage in +/-4 steps of 2.5 % each.

### Proposed parameters of the OLTC controller:

Parameter Value Voltage set point [V] 230 (phase-earth)

Bandwidth [%] 2.5

Delay time  $T_d$  [s] 10

Under-voltage blocking [% of voltage set point] 80

The transformer LV-busbar feeds the control cabinet of the smart transformer. Hence, the LVRT test stresses the control cabinet as well.



Figure 4. Smart transformer in the Test Bay.

Control box on the left bottom corner of the picture.

### Test results

The new smart transformer has been assessed under different voltage dip conditions, according to grid code specifications, proving that the OLTC control box was not disconnected after any of the tested dips. Different control algorithms (normal, advanced) have been checked under a set of different operation conditions (normal, quick, blocked). In addition, reverse power flow conditions, in the case that distributed DG exceed the LV loads, has been tested along with remote sensors devices.

The following test cases were performed:

- Commissioning Tests.
- Voltage Dip. Normal operation. 0.975-0.9 p.u. Using only decoupling.
- Voltage Dip. Quick operation. 0.9-0.8 p.u.
- Voltage Dip. Blocked operation. 0.9-0.8 p.u.

- Advanced algorithm
- Feed-in (PV-generation)

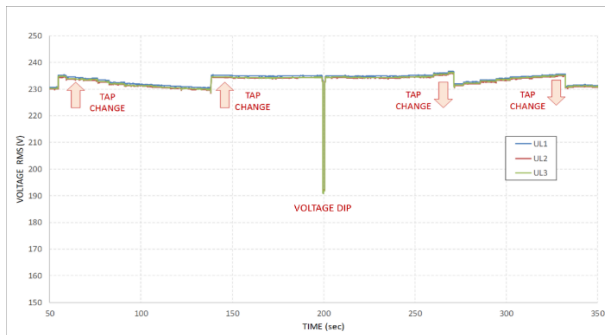

Figure 5. Voltage Dip. Quick operation. 0.9-0.8 p.u. No operation during voltage dip and operation afterwards (3-phases).

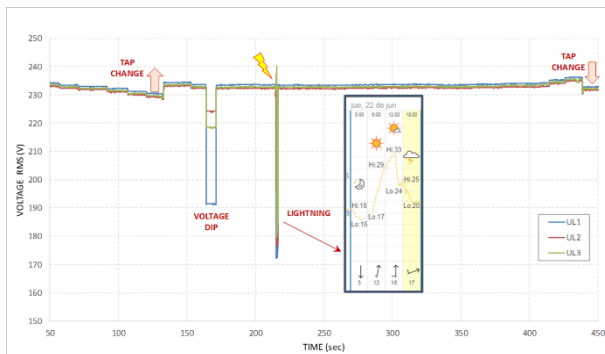

Figure 6. Voltage Dip. Quick operation. 0.9-0.8 p.u. No operation during voltage dip and operation afterwards, including a lightning<sup>4</sup> (2-phases: R,S).

## CONCLUSIONS

The capability to withstand the LVRT tests of the control box of a smart distribution transformer with OLTC has been tested in the Smart Grid test centre SysTec of Fraunhofer IEE.

In addition to the existing test procedures, which are in accordance with current standards and application requirements, the performed investigations might serve to further develop the grid connection rules.

Moreover, the performed tests and assessments showed that the new smart distribution transformer is able to cope with voltage instabilities and fluctuations, keeping the voltage within the statutory limits.

The smart distribution transformer with OLTC can be considered as an essential element of distribution networks that can provide optimal grid flexibilities and reliability.

## Acknowledgments

The authors of this research work wish to acknowledge the ERIGrid consortium as well as the European Commission for its support. <https://erigrd.eu/>

## REFERENCES

- [1] The "20-20-20" targets, Overview of EU climate and energy policies.
- [2] COP21, Paris Climate Conference, 2015.
- [3] Ren21's, Renewables 2013, Global Status Report.
- [4] UNEP Collaborating Centre for Climate & Sustainable Energy Finance, Global Trends in Renewable Energy Investment 2014.
- [5] EN 50160:2011. Voltage characteristics of electricity supplied by public distribution systems.
- [6] J. Schmiesing, H. Beck, T. Smolka, M. Sojer. *Avoiding MV-Network Expansion by Distributed Voltage Control*, in the 22nd CIRED, Jun 2013.
- [7] T. Smolka, D. Dohnal, M. Sojer, R. Heiliger, J. Schmiesing, T. Hug, F. Sutter. *Advanced Grid Integration of Dispersed Generation by using Voltage Regulated Distribution Transformers (VRDT)*. CIGRE Session 2014.
- [8] T. Drizard, C. Lebosse, B. Chazottes. *Integration of Distributed PV Generation: The Nice Grid Project*, in the 23rd CIRED, Jun 2015.
- [9] S. Huang, J. Pillai, M. Liserre, B. Bak-Jensen. *Improving photovoltaic and electric vehicle penetration in distribution grids with smart transformer*. IEEE PES Innovative Smart Grid Technologies Europe 2013.
- [10] L. Del Río Etayo, P. Cirujano, P. Lauzevis, G. Pérez de Nanclares, A. Soto, A. Ulasenka, *A new smart distribution transformer with OLTC for low carbon technologies integration*, paper n° 0832, in the 24th CIRED, June 2017.
- [11] IEC 60076-1:2011. Power transformers.
- [12] IEC 60214-1:2014. Tap-changers.
- [13] IEC 61000-4-1. Electromagnetic compatibility (EMC).
- [14] Commission Regulation (EU) No 548/2014 of 21 May 2014 - Directive 2009/125/EC of the EP and of the Council with regard to small, medium and large power transformers.

<sup>4</sup> The test was performed during a thunderstorm in Kassel (Fraunhofer IEE).